



PRO Technical Regulations

2015

International Version 2.0



THE #1 Dog-Box & Quick Change Rear End Facility in US, Supporting Race Teams WORLD-WIDE! We Cover Parts, Service & Full Rebuilds !

ALL Formula Drift Teams receive a 10% discount on ALL Services ** During the Off Season **

The RTS Difference:

31 years of Proven Pro-Level Racing Experience
Indy Car (16), Nascar (5), Road Racing (5), Formula Drift (5)
81 Wins, 5 Championships in Various Pro-level Racing Series Worldwide.



RTS Superior Dog-Boxes & Diffs:

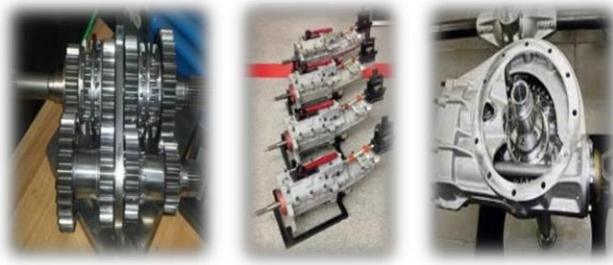

- RTS/GSR Built Transmissions (ALL Andrews Internals!)
- RTS/MID-VALLEY Built Transmissions (Hewland Internals)
- RTS/Ford 9" Diffs (2.75 / 6.50 ratios / Light Weight Pkgs)
- Winters or Speedway Quick Change IRS Setups
- Winters Quick Change Solid Axle Setups

RTS Can Help in "Every Aspect" Regarding "YOUR" Pro-Racing Needs!

RTS FULL SERVICE: New Race Car builds, Kit-Car Builds, Custom Engines 500hp - 1400hp, Machine Shop, Full Fabrication, **Weekend Crew Support & Race Car Prep**

Dog Box services currently basic is \$400 plus parts, Full Rebuild is \$600 plus parts.

Quick Change Rear services currently are the same price as above. PLUS our turn-around times on Dog Boxes or QC Diffs are second to none!!! Ask any of our clients!



RTS-GSR Dog Boxes (All Andrews Internals) can handle 1000+HP, Customized delivered to your doorstep RACE READY, ANY ratio stack! Just add 32oz of oil & RACE! **Current Price is \$5,450.00 delivered anywhere in US!**

RTS Quick Change Rears can handle 1000+HP, Custom Ratios & Diff options for you, delivered to your doorstep RACE READY. **Current Price \$3,774.00 delivered anywhere in US! *Additional costs required on all international sales***



www.RACETECHSERVICESINC.COM or RaceTechServices@Gmail.com

RTS inc. 580 W Lambert Rd, Suite # J, Brea, CA. 92821 / Ph: 714-290-5276 / Rick Lamber Jr

Table of Contents

	Introduction.....	5
1.	TECHNICAL INSPECTION.....	6
	1.1. ELIGIBILITY INSPECTIONS	6
	1.2. MODIFICATIONS	7
	1.3. DAMAGE	7
	1.4. TEAM REPRESENTATIVE	7
2.	COMPETITION VEHICLES.....	7
	2.1. VEHICLE ELIGIBILITY	7
3.	CHASSIS	8
	3.1. CHASSIS MODIFICATIONS	8
	3.2. ROLL CAGE	11
	3.3. BALLAST	20
4.	SUSPENSION AND BRAKES.....	21
	4.1. FRONT SUSPENSION	21
	4.2. STEERING	22
	4.3. REAR SUSPENSION- LIVE AXLE	22
	4.4. REAR SUSPENSION- INDEPENDENT	23
	4.5. BRAKE SYSTEM	24
	4.6. Wheels	24
5.	DRIVETRAIN.....	24
	5.1. ENGINE	24
	5.2. COOLING SYSTEM	24
	5.3. OIL SYSTEM	24
	5.4. FUEL SYSTEM	25
	5.5. NITROUS OXIDE	26
	5.6. EXHAUST SYSTEM	26
	5.7. STARTER	26
	5.8. TRANSMISSION	26
	5.9. DRIVESHAFT	26
	5.10. TRACTION CONTROL	27
	5.11. DATA	27
	6.1. BATTERY	27
	6.2. MASTER-CUTOFF	28
7.	BODY EXTERIOR AND INTERIOR	28
	7.1. BODY PANELS	28
	7.2. WING	29
	7.3. WINDSHIELD	29
	7.4. WINDOWS and WINDOW RESTRAINTS	29
	7.5. WIPERS	30
	7.6. MIRRORS	30
	7.7. HOOD PINS	30
	7.8. DECALS	30
	7.9. TOWING APPARATUS	31
	7.10. LIGHTS	33
	7.11. INTERIOR	33
	7.12. DASHBOARD	33
	7.13. STEERING WHEEL	33
8.	DRIVER'S SAFETY EQUIPMENT	33
	8.1. HELMET	33
	8.2. DRIVING SUIT	34
	8.3. EYE GLASSES	34
	8.4. SEATS	35
	8.5. SEAT BELTS	35
	8.6. ARM RESTRAINTS	37
	8.7. HEAD AND NECK RESTRAINTS	37
	8.8. FIRE SUPPRESSION SYSTEM	38
9.	TIRES	38
	9.1. TIRE ELIGIBILITY	38
	9.2. APPROVED TIRES	38
	9.3. TIRE SIZE REGULATIONS	38
	9.4. TIRE TO WEIGHT COMPLIANCE	38

9.5. TIRE MEASURING PROCEDURE	38
9.6. TIRE MODIFICATION	38
9.7. TIRE CLAIMING	38
9.8. REQUESTING TIRE ELIGIBILITY	38

Introduction

We are pleased to provide you with the 2015 edition of the International Technical Regulations. This edition provides the Technical Regulations for the FORMULA DRIFT Championship Rounds conducted outside of the United States.

If you require Technical Regulations for the Formula Drift Rounds conducted in the United States, please contact the technical department.

This edition of the rules establishes the foundation for the organization and conduct of the FORMULA DRIFT International Championship rounds. Participants, teams, drivers, and officials are strongly encouraged to review these rules carefully.

FORMULA DRIFT Holdings, LLC

2161 Gundry Avenue
Signal Hill, CA 90755
562-901-2600 (phone)

General Inquiries

info@formulad.com

Technical Inquiries

kevin@formulad.com

Media Inquiries

john@theidagency.com



The
FUN
starts
with **K&K**

As a trusted provider of motorsports insurance, K&K is committed to helping your business succeed by offering high-quality coverage and services designed for your needs. K&K's expertise is respected throughout the industry; we are your solution for affordable insurance coverage. It's easy to work with K&K—visit our website now for more information.

- Professional Teams
- Amateur Teams
- Owners & Sponsors
- Drivers
- Facilities & Events
- Racing Service & Repair Shops



- Competitive rates and coverage
- Extensive specialty insurance and claims knowledge
- Secure market with over 60 years of experience

Products Liability Coverage

For Manufacturers, Importers, and Distributors of:

- Racing equipment & parts
- Critical auto parts
- Street rods, kit cars & collector car kits
- Auto, motorcycle & truck parts

K&K
INSURANCE
Insuring the world's fun!

800.348.1839
www.kandkinsurance.com

1. TECHNICAL INSPECTION

1.1. ELIGIBILITY INSPECTIONS

ANNUAL INSPECTIONS-

Prior to the first time a vehicle is entered into any EVENT for the current season; the TECHNICAL MANAGER will issue a FORMULA DRIFT VEHICLE IDENTIFICATION (VID) number/sticker and conduct an annual inspection of each vehicle. Upon verification of compliance to the rules, an annual tech sticker will be issued and affixed to the main roll bar hoop at driver's left. Only vehicles that have passed the annual inspection, and have an annual tech sticker affixed, will be allowed to compete unless approved by the TECHNICAL MANAGER.

Issuance of the tech sticker is not an endorsement of the performance of the vehicle, nor an indication that the vehicle meets all of the required Technical Specifications. The tech sticker signifies that the vehicle has passed the initial Safety Inspection and will be permitted to go on course during scheduled FORMULA DRIFT practice, qualifying and drift sessions.

The annual tech sticker will be withheld from any vehicle that does not comply with the required Safety Specifications. If the tech sticker is withheld, it is the team's responsibility to meet with the TECHNICAL MANAGER to determine what action is required to achieve compliance. The TECHNICAL MANAGER shall maintain inspection records of each entered vehicle.

To be eligible for competition in an EVENT, all vehicles must have:

A FORMULA DRIFT VEHICLE IDENTIFICATION number (VID)

A current annual technical inspection sticker

EVENT INSPECTIONS-

At a time and place and in a manner determined by event officials, prior to racing activities of any nature (including without limitation qualifying, competition, practice, testing etc.) all vehicle and driver equipment must undergo a technical inspection.

In addition, every vehicle is subject to further technical inspection at any time before, during or after an event, at the time and in the place and manner directed by any event official. Formula Drift may at any time inspect, seal for inspection, and/ or tear down a participant's vehicle. Not complying in full with any inspection request will result in disqualification for further competition and such other penalties as deemed appropriate by Formula Drift. All determinations by event officials regarding the timing and method of technical inspection shall be final and not subject to appeal or review.

Technical inspection assists event officials with determining, in their judgment, eligibility for participation in an event. The technical inspection does not in any way change the fact that the driver, the crewmembers, and the vehicle owner are ultimately responsible for the safety and operation of the vehicle and equipment.

The participant agrees that participant is in the best position to know about the construction and operation of participant's vehicle, equipment, and clothing, and whether there has been compliance with all Formula Drift rules, regulations and agreements, including but not limited to those contained in the Rulebook. Moreover, in the case of technical violations, the participant acknowledges, understands and agrees that the participant is charged with full knowledge of every component of participant's vehicle and that even if a third party has caused the participant's vehicle to be noncompliant, the participant will still be responsible for and charged with any applicable violation and sanction. Disclaiming knowledge of the particular part or parts, or disclaiming knowledge of the rule or rules, or disclaiming responsibility for the actions of the third party, will not be defenses to any violation or any sanction therefor.

RETENTION OF VEHICLES AND PARTS-

Participant hereby grants Formula Drift, and each of their agents and assigns, full and unconditional permission to collect and retain vehicles, parts of vehicles, equipment, or any other Items used in conjunction with participation that are owned by or in the possession of participant or present at an event (collectively "Items"), including such Items that may be relevant incident to the investigation of an incident; the inspection or testing of such Items; or for any other purpose. Formula Drift may exercise this right to take and retain Items at any time when Formula Drift determines in its sole and absolute discretion that such actions are necessary. Participant fully releases Formula Drift from any liability whatsoever for loss of, damage to, or destruction of any such Items. When an item is suspected of being out of compliance with an Formula Drift rule, or when an item has been involved in an incident, Formula Drift may in its sole and absolute discretion collect and retain such Items if Formula Drift believes it necessary to do so to further investigate, make a final determination, and/or preserve evidence, all in Formula Drift's sole and absolute discretion. At any time that Formula Drift collects and retains Items, Formula Drift will try to safeguard such Items and return such Items when Formula Drift has completed its work with them, but Formula Drift makes no representation or warranties that the Items will not be lost, damaged, destructively tested, destroyed or otherwise affected. Formula Drift is not responsible for payment, reimbursement, damage or loss to the participant as a result of compliance testing. If Formula Drift believes that an item should be retained or destroyed, or indefinitely or permanently retained, to prevent further use of such item in competition, Formula Drift may so retain or destroy such item.

PARTICIPANT OBLIGATIONS-

Participants must take whatever steps are requested by a Formula Drift Official, including tear down of the vehicle and removal of parts to facilitate inspection of race equipment. This obligation includes, but is not limited to, installing inspection holes, inspections ports, and/or other means of inspections in the frame, roll cage bars, suspension components, and the like. Formula Drift is not responsible for payment, reimbursement, damage or loss to the participant as a result of such inspections.

MAINTENANCE OF ELIGIBILITY-

It is the responsibility of the team to maintain a vehicle's eligibility.

1.2. MODIFICATIONS

Any vehicle which after being issued an annual technical inspection sticker by the TECHNICAL MANAGER is dismantled, or modified, or in any way changed which might affect its safety or call into question its eligibility, or which is involved in an accident with similar consequences, must be re-presented by the team for approval. It is the responsibility of the team to notify the TECHNICAL MANAGER of any modifications.

1.3. DAMAGE

If a vehicle is damaged due to an accident or other incident, the TECHNICAL MANAGER may remove the annual tech sticker. A new tech sticker may be issued after the vehicle is re-inspected or repaired and then re-inspected. It is the responsibility of the team to notify the TECHNICAL MANAGER of any and all damage.

1.4. TEAM REPRESENTATIVE

During Technical Inspection, there may only be one person from the team serving as a representative for the vehicle being inspected. The area should be closed off and private. All other personnel must leave area.

2. COMPETITION VEHICLES

2.1. VEHICLE ELIGIBILITY

Eligible models must be considered a "production vehicle" and have had a minimum build run of 600 units in each model year.

Eligible body styles include: coupe, sedan, convertible or wagon and have no more than 5 doors.

Vehicles must maintain the original OEM steel unibody and/or steel frame structure between the OEM front and rear suspension mounting points.

No trucks or SUVs will be allowed.

Vehicles that do not meet the above eligibility criteria must petition for approval from FORMULA DRIFT.

3. CHASSIS

3.1. CHASSIS MODIFICATIONS

The original OEM floorpan, frame and or unibody must remain unmodified between the vertical planes created by the original forward most and rear ward most suspension point or subframe mounting point. Front suspension examples are in Figure 1 and 2. Rear suspension examples are in Figures 3 and 4.

Unibody or chassis may be stitch or seam welded.

Plating of chassis is prohibited.

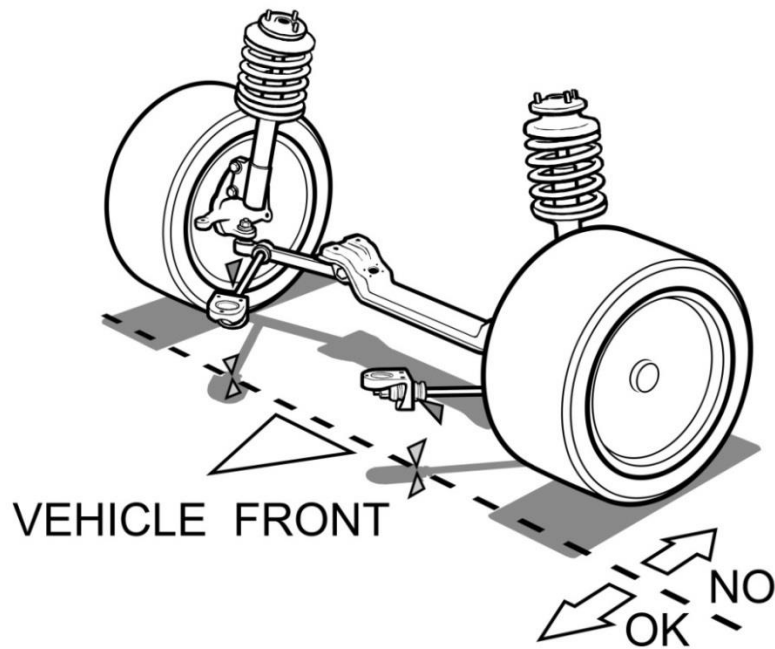

Figure 1

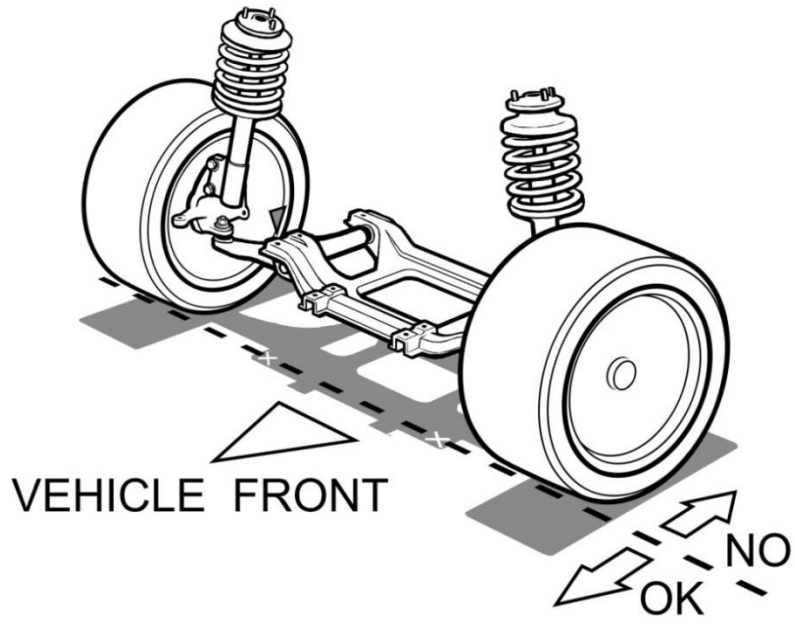

Figure 2

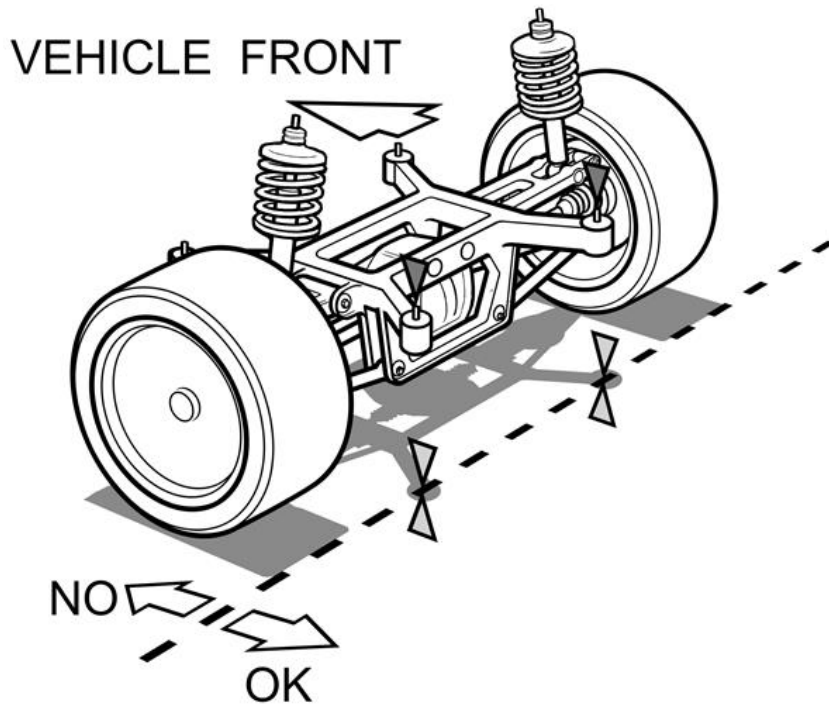

Figure 3

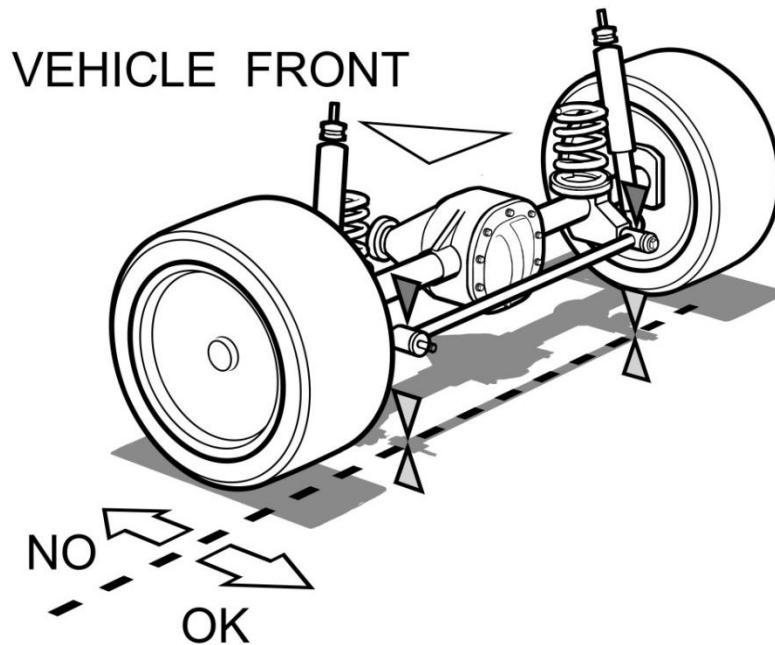

Figure 4

The original OEM floorpan, frame and or unibody must remain unmodified between the horizontal planes created by the original floorpan at the lowest horizontal plane to the roof at its highest horizontal plane. With the exception of transmission tunnel and firewall dimensions listed below and Fuel cell rule.

Items in the unmodified zone that are allowed to be removed can include original rear window parcel shelf, tabs or mounts for unused OEM steering columns, unused OEM windshield wiper mounts, and the exterior roof panel can be replaced with a composite panel.

Rear suspension tower cross-members located at the top of the rear suspension towers may be removed from the unibody interior only if a suitable replacement structure of equivalent strength is installed.

No part of the engine casing may cross the vertical threshold of the original firewall into the transmission tunnel.

No other modifications may be made to the vehicle chassis, frame, or unibody.

Any holes in the firewall must be of the minimum size for the passage of controls and wires, and must be completely sealed to prevent the passage of fluids or flames from the engine compartment to the drivers compartment.

FIREWALL AND TRANSMISSION TUNNEL MODIFICATIONS-

Modifications of the stock, OEM firewall and transmission tunnel are in Figure 5:

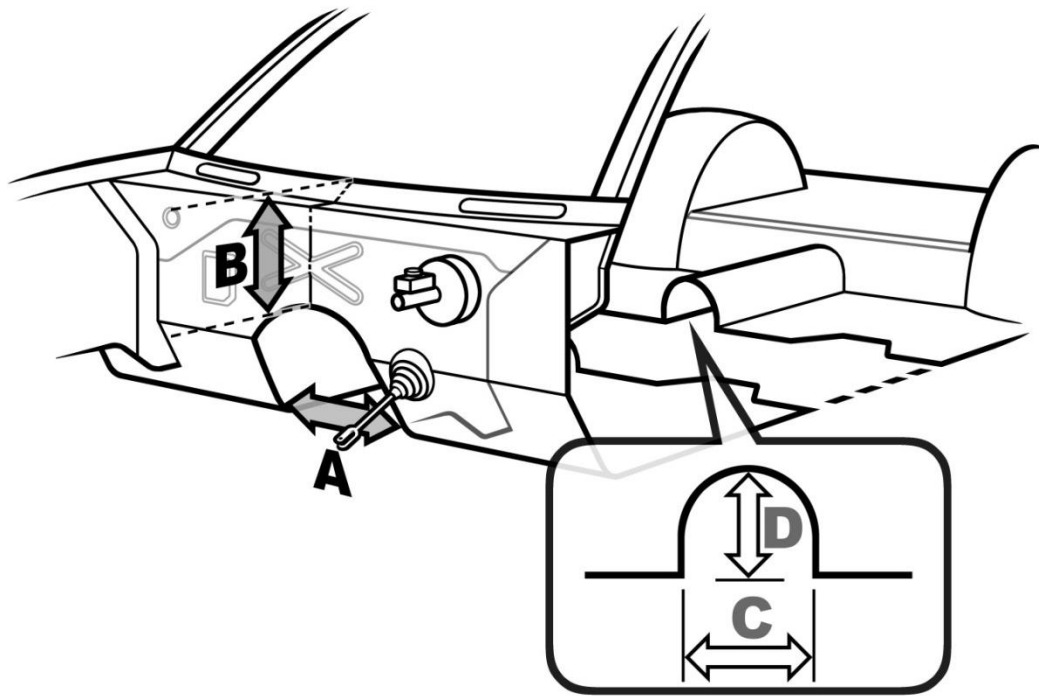

Figure 5

Dimension A: Tunnel Width may be no wider than 18 inches (457.2 mm)

Dimension B: Minimum dimension of 10 inches (254 mm) between the bottom of the windshield and the top of the transmission tunnel.

Dimension C: Modifications to drive shaft tunnels behind the engine firewall vertical plane should not exceed an overall width of 10.000 inches (254mm).

Dimension D: Modifications to drive shaft tunnels behind the engine firewall vertical plane should not exceed an overall width of 10.000 inches (254mm).

Taper Length from the firewall to the end of the transmission tunnel into the beginning of the drive shaft hump may be no longer than 36 inches (914.4 mm).

Modifications to firewall and transmission tunnel must be done with .036-inch (.9144mm) steel or .059-inch (1.4986 mm) aluminum.

3.2. ROLL CAGE specifications listed below apply only for 2015 International Rounds (NON USA)

GENERAL-

All roll cage structures must be designed in an attempt to protect the occupants from any angle, 360 degrees. The roll cage shall attach to the chassis/unibody in a minimum of 6 points.

Bolt in roll cages compliant with FIA standards and regulations are allowed.

The safety cage structure shall not unduly impede the entry or exit of the driver/crew.

Any tube forming part of a safety cage structure shall not carry fluids or any other materials.

SAFETY CAGE KITS- Despite some manufacturers' claims, not every safety cage structure built from a commercially available 'kit' complies with the current FIA regulations.

MATERIAL SPECIFICATIONS-

Material	Minimum tensile strength	Minimum dimensions	Use
Cold drawn seamless (CDS) or Cold drawn welded (CDW) unalloyed carbon steel	350 N/mm ²	Metric: 44.45mm x 2.5mm or 50 x 2.0mm	Main Roll bar and Lateral Bars
		Metric: 38mm x 2.5mm or 40mm x 2.0mm	Lateral Half Roll Bars and other parts of the safety cage

STEEL TYPE AND COMPOSITION- The steel shall be cold drawn seamless (CDS) or cold drawn welded (CDW) unalloyed carbon steel containing a maximum of 0.3% of carbon, with adequate elongation and weldability properties. For an unalloyed steel, the maximum content of additives is 1.7% for manganese and 0.6% total of all other elements.

TUBE PROFILE- Only tubes with a circular section are permitted.

MATERIAL NOT IN COMPLIANCE- Formula Drift may accept other steels and sizes not in compliance with this article through the process of safety cage structure certification.

BENDING-

The tubing shall be bent by a cold working process and the centreline bend radius shall be at least three times the tube diameter.

If the tubing is ovalized or otherwise distorted during bending, the ratio of minor to major diameter shall be 0.9 or greater.

The surface of the tube at the bend shall be smooth and even, without ripples or cracks.

WELDING-

Welding shall be carried out along the whole perimeter of each tube joint and shall be of the highest possible quality with full penetration, preferably using a gas-shielded arc.

Although good external appearance of a weld does not necessarily guarantee its quality, a weld of poor appearance may indicate that it is unsatisfactory.

When using heat-treated steel any special instructions of the tube manufacturer shall be followed (eg, ambient temperature, special electrodes, gas protected welding).

PADDING-

Padding must meet SFI spec 45.1 or FIA 8857-2001. Padding is required anywhere driver helmet may come in contact with the roll cage.

BASIC STRUCTURE-

The basic structure must be made according to one of the following designs:

- 1 main roll bar + 2 lateral half roll bars + 1 transversal member + 2 backstays + 6 mounting feet (Figure J-2)
- 1 main roll bar + 1 front roll bar + 2 longitudinal members + 2 backstays + 6 mounting feet (Figure J-3)
- 2 lateral roll bars + 2 transversal members + 2 backstays + 6 mounting feet (Figure J-4).

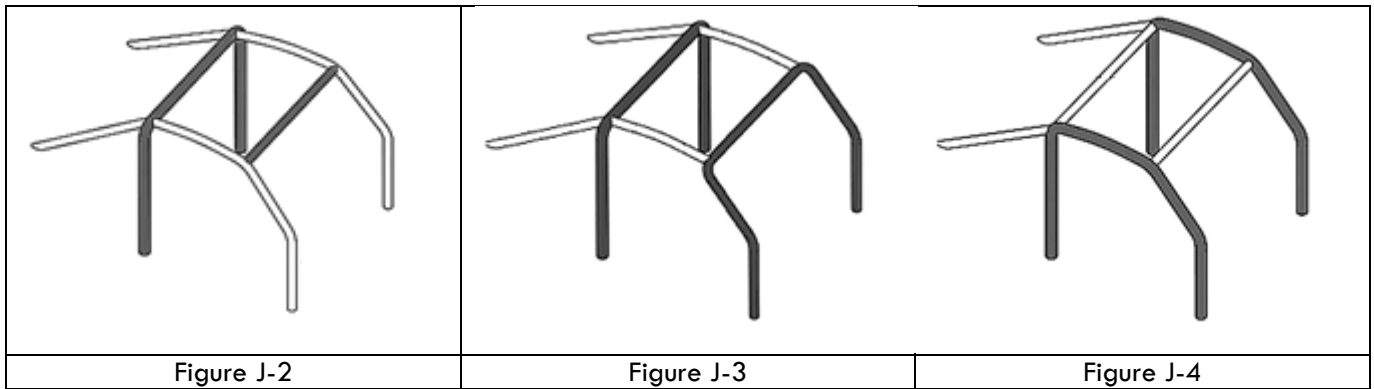

The vertical parts of the main roll bar must be as close as possible to the interior contour of the bodyshell and may have only one bend in each lower near-vertical part.

Only one bend is permitted in the front leg of a front roll bar or of a lateral roll bar. The front leg must follow the windscreen pillar as closely as possible with the sole bend in its lower near-vertical part. For non- international competition, the front leg may depart from the contour of the windscreen ('A') pillar to enable it to be located rearward of the dashboard. The sole bend permitted in the front leg may be incorporated in its upper part, to enable it to follow the windscreen pillar.

Each connection between a lateral half roll bar and the main roll bar (J-2), between a longitudinal member and a front or main roll bar (J-3), and between a transversal member and a lateral roll bar (J-4) shall be situated at the roof level.

There shall be not more than four removable connections in the basic structure at the roof level.

Please note: any removable connection fitted at the top of a backstay is not considered to be at roof level. Each backstay shall be attached to the main or lateral roll bar near the roofline and near the top outer bend on each side of the vehicle. A removable connection may be used. Each backstay must form an angle between 30° and 60° with the vertical, must run rearwards and be straight and be as close as possible to the interior side panels of the bodyshell.

DIAGONAL MEMBER- the safety cage structure shall be configured in accordance with Figure J-5 and J-6 incorporating at least one diagonal member, the diagonal shall have the upper end attached on the driver's side.

Each diagonal member shall be straight and may be removable.

For Figure J-5 the upper end of the diagonal member shall join the main roll bar no further than 100mm from its junction with the backstay.

For Figure J-6 the upper end of the diagonal member shall join the backstay no more than 100mm from its junction with the main roll bar. See Figure J-62 for the measurement.

The lower end of the diagonal shall join the main roll bar or the backstay no further than 100mm from the mounting foot.

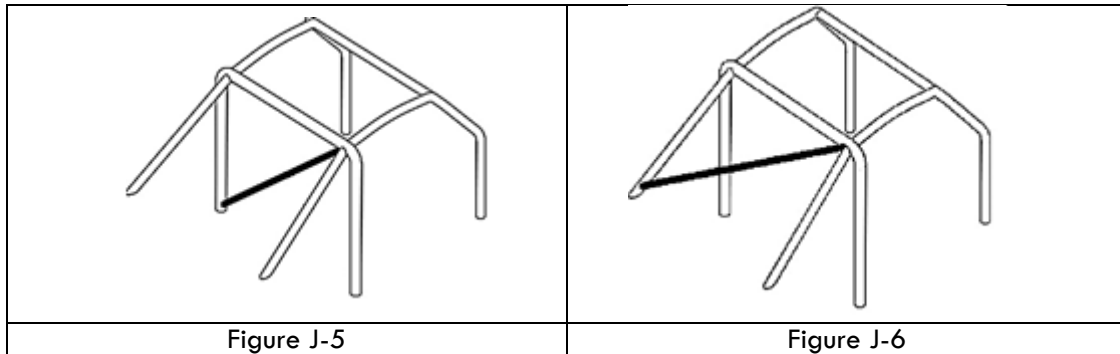

DOOR BARS-

Two or more door bars must be fitted at each side of the vehicle according to Figure J-11, J-12 or J-13.

Door bars may be removable, subject to the use of dismantable joints complying with specifications listed under removable members. The side protection shall be as high as possible, subject to its upper attachment point not being higher than half the height of the door opening measured from its base.

In the case of doorbars in the form of an "X" (Figure J-11), it is recommended that the "X" be formed by two continuous bars which are joined in the centre. It is recommended that this join be reinforced by two gussets.

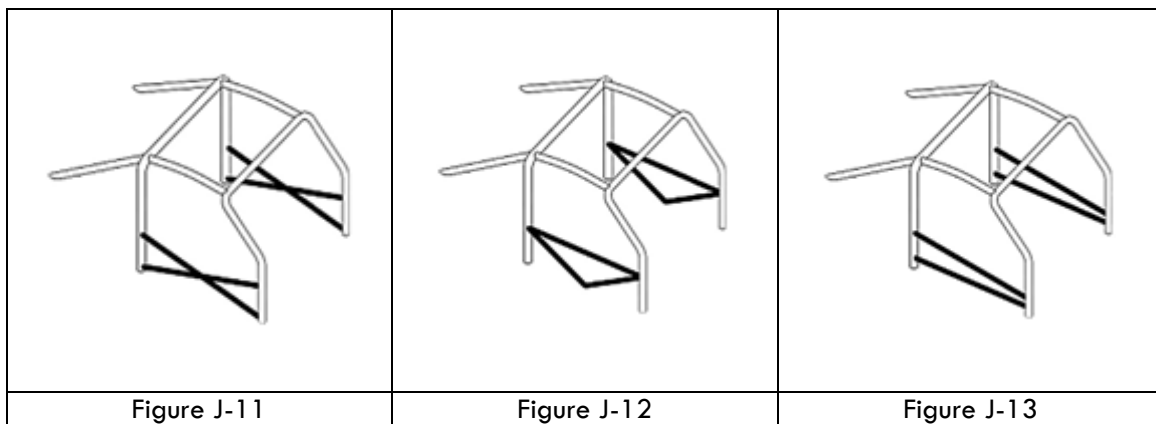

REMOVABLE MEMBERS-

Removable members may be incorporated subject to the use of dismantable joints complying with Figure

J-47 to J-57. Such joints shall not be welded once assembled. Any fastener used shall have a minimum quality of 8.8 (ISO standard).

Dismountable joints complying with Figures J-47, J-50, J-53, J-56 and J-57 shall be used only for attaching optional members and reinforcements described by Article 12.2. They are **not permitted** for joining the upper parts of the main roll bar, the front roll bar, the lateral half roll bars or the lateral roll bars (refer Figure J-2, J-3 and J-4).

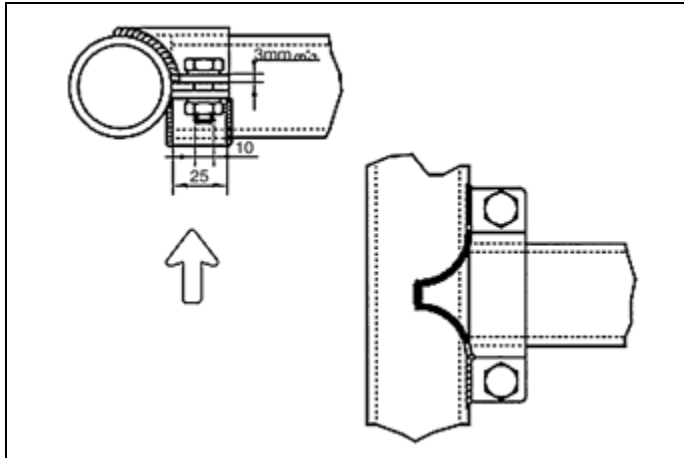

Figure J-47

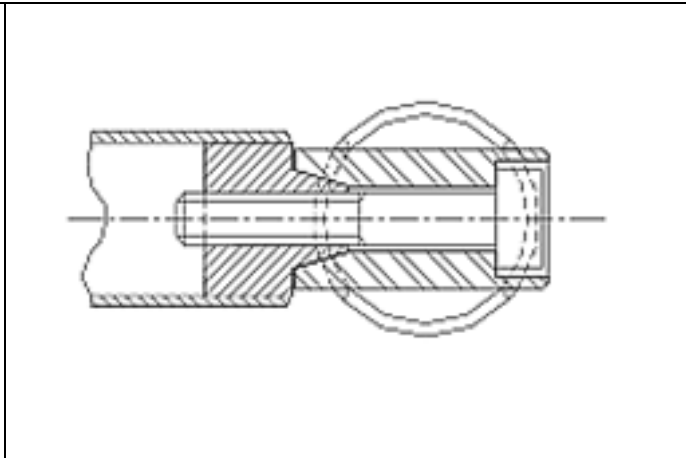

Figure J-48

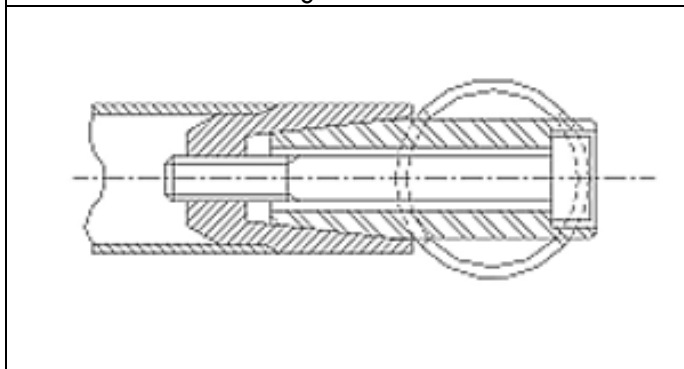

Figure J-49

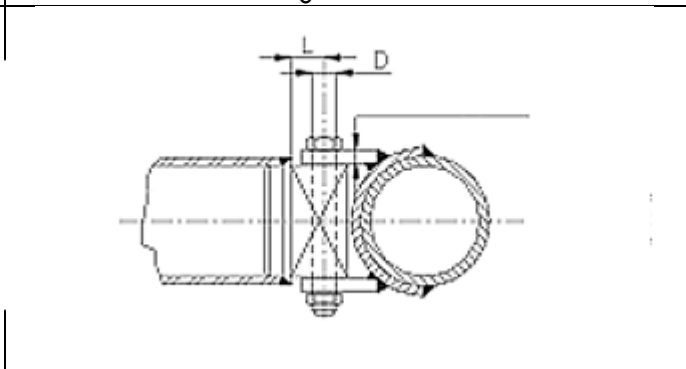

Figure J-50

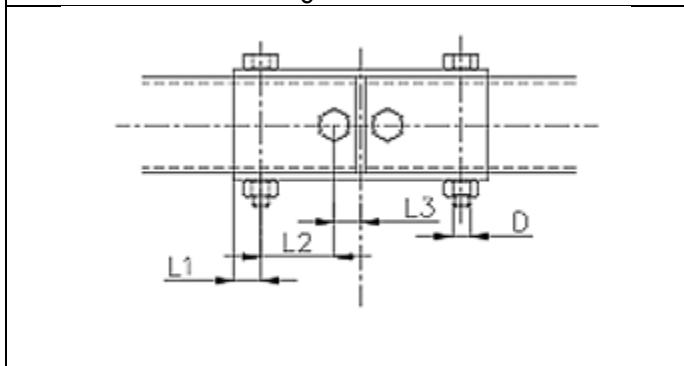

Figure J-51

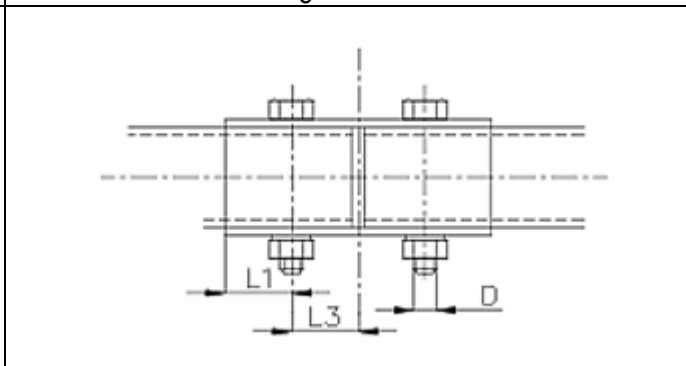

Figure J-52

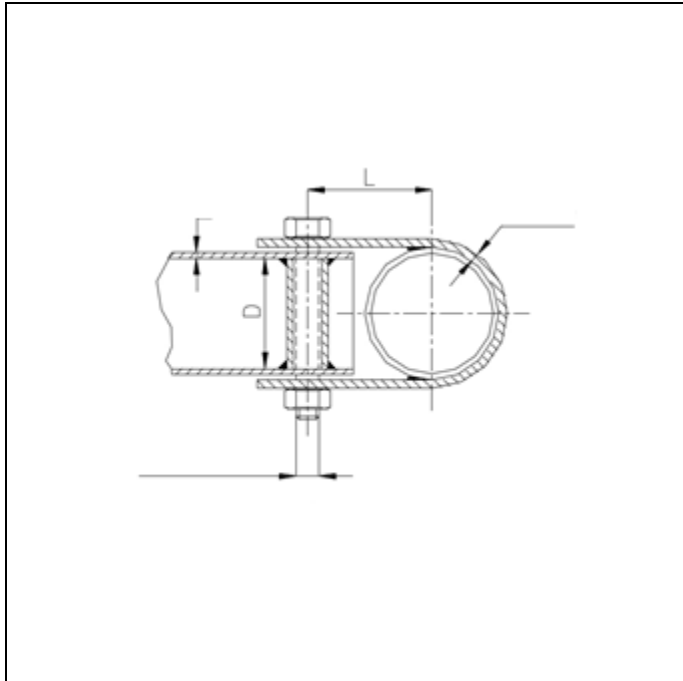

Figure J-53

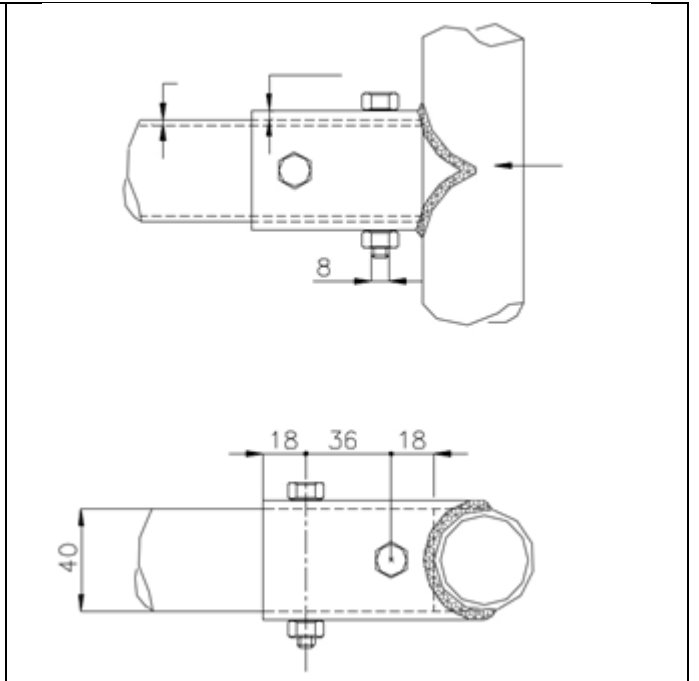

Figure J-54

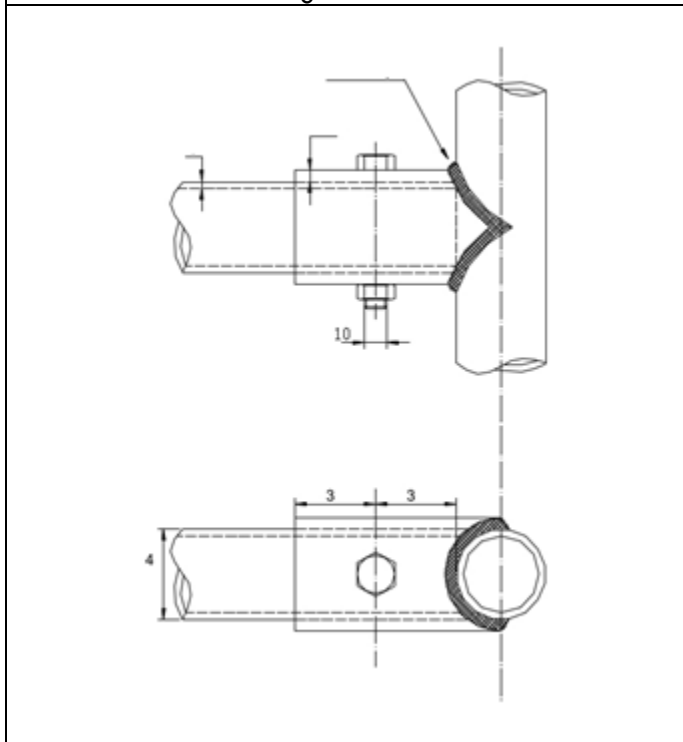

Figure J-55

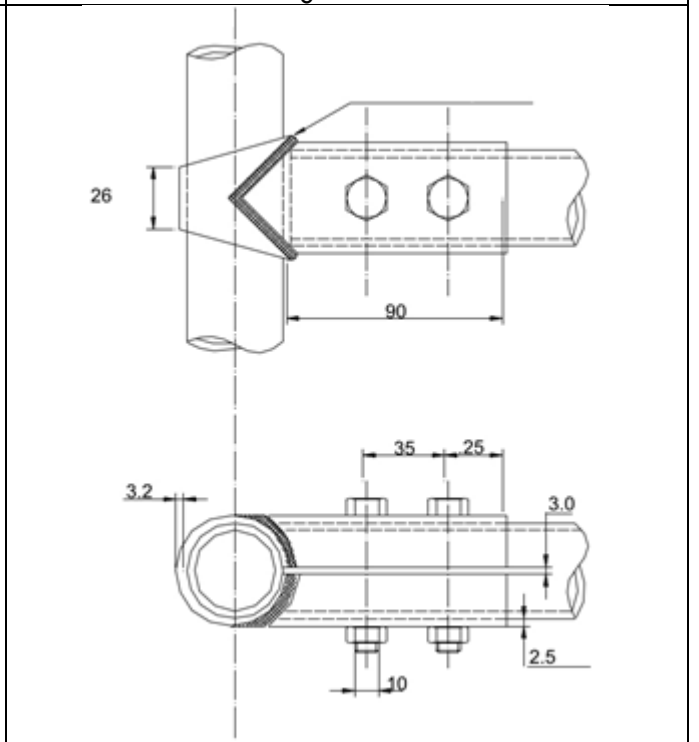

Figure J-56

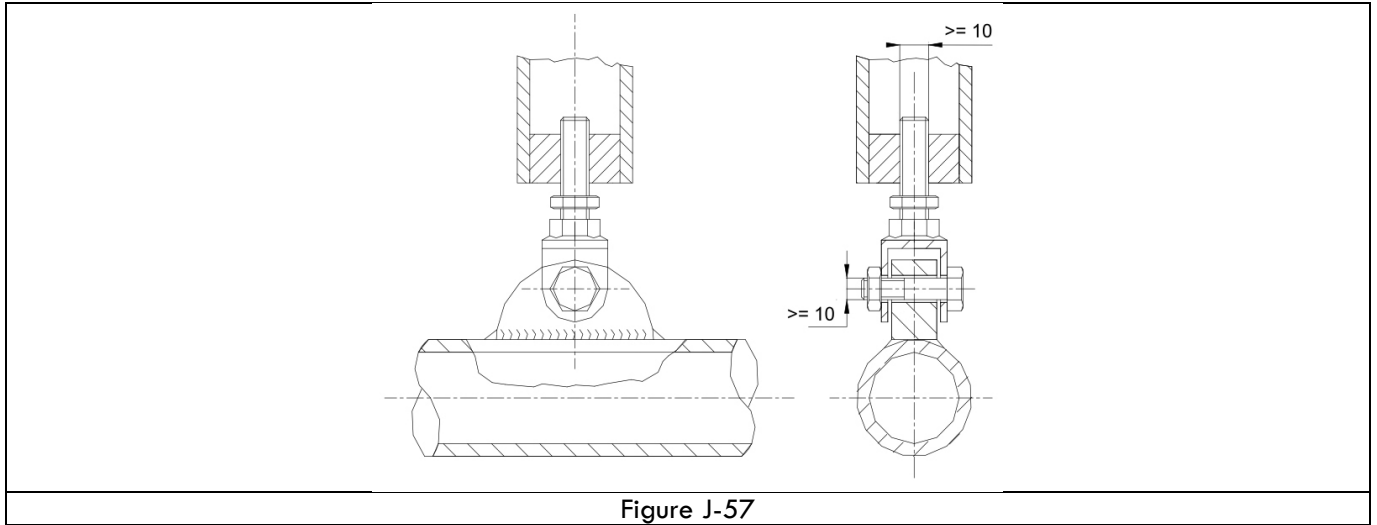

Figure J-57

MOUNTING OF THE SAFETY CAGE STRUCTURE TO THE BODY SHELL/CHASSIS-

MINIMUM MOUNTING POINTS-

The minimum mounting points are:

- one for each pillar of the front roll bar;
- one for each pillar of the lateral roll bars or lateral half roll bars;
- one for each pillar of the main roll bar;
- one for each backstay.

MOUNTING POINTS OF THE FRONT, MAIN AND LATERAL ROLL BARS OR LATERAL HALF ROLL BARS-

Each mounting point shall include a mounting foot consisting of a plate at least 3mm thick.

Each mounting foot shall be attached by at least three bolts to a steel reinforcement plate at least 3mm thick and of at least 120cm² area which is welded to the bodyshell. Where attached by bolts, the angle between any two bolts shall not be less than 60° (measured from the tube axis at the level of the mounting foot circumference – Figure J-60).

The area of 120cm² of the reinforcement plate shall be the contact surface between the reinforcement plate and the bodyshell. Refer Figure J-60 to J-66. For Figure J-62 the reinforcement plate need not be welded to the bodyshell.

Fasteners shall have a minimum diameter of M8 and a minimum quality of 8.8 (ISO standard) and shall be self-locking or fitted with lock washers.

As an alternative to welding reinforcement plates to the chassis of the vehicle, each attachment point of the safety cage structure may be fitted with a mounting foot and lower plate complying with the Table below (see also Figure J-69). The mounting foot, complying with the area requirements shown below may be welded to the bodyshell, in which case the use of bolts and the lower plate is not required (see Figure J-70).

Application	Minimum Area	Minimum Single Dimension
Mounting foot Vehicles under 700kg 701kg to 1150kg Over 1151kg	65cm ² 75cm ² 100cm ²	55mm 65mm 75mm
Lower plate	45cm ²	Matching upper plate

MOUNTING POINTS OF THE BACKSTAYS-

Each backstay shall be secured by at least two M8 (minimum) 8.8 (ISO standard) bolts with mounting feet of an area at least 60cm² (refer Figure J-67). Alternatively it shall be secured by a single M10 8.8 (ISO standard) bolt in double shear (refer Figure J-68), provided each mounting plate is at least 3mm thickness steel with a bush fully welded into the backstay.

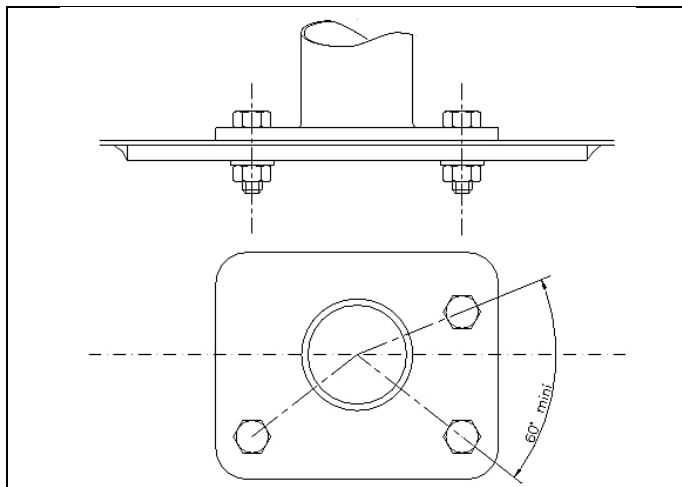

Figure J-60

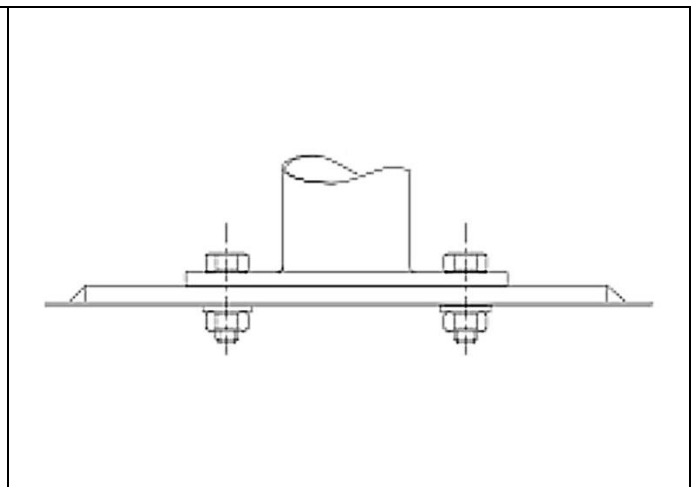

Figure J-61

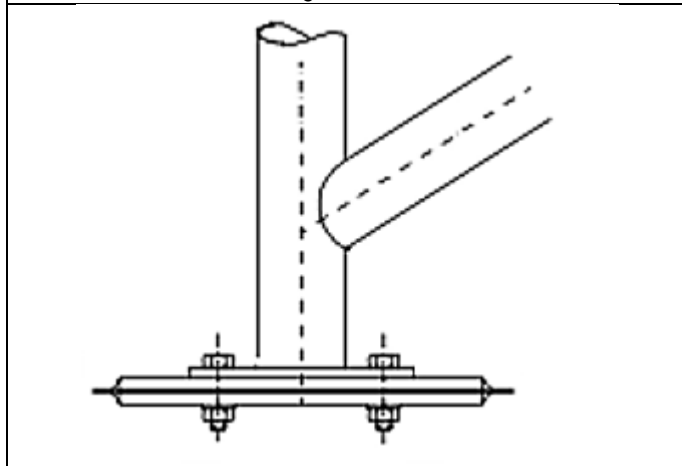

Figure J-62

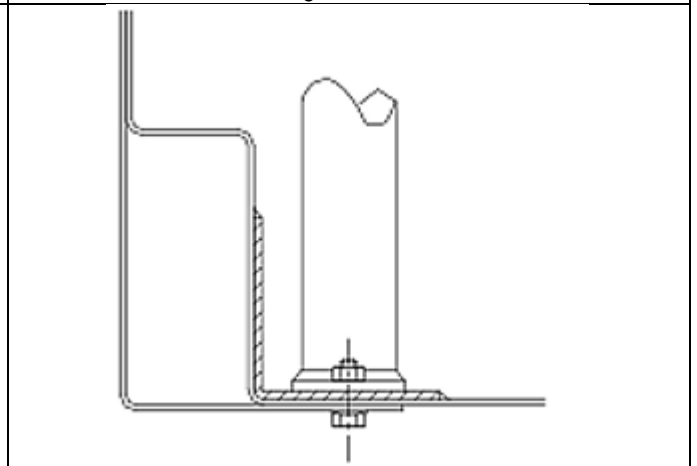

Figure J-63

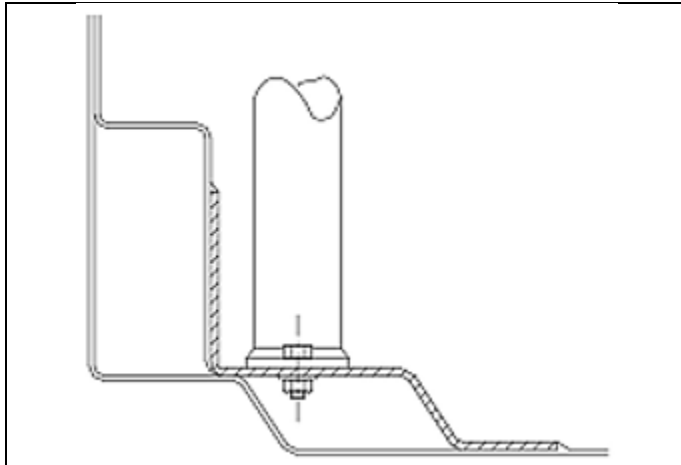

Figure J-64

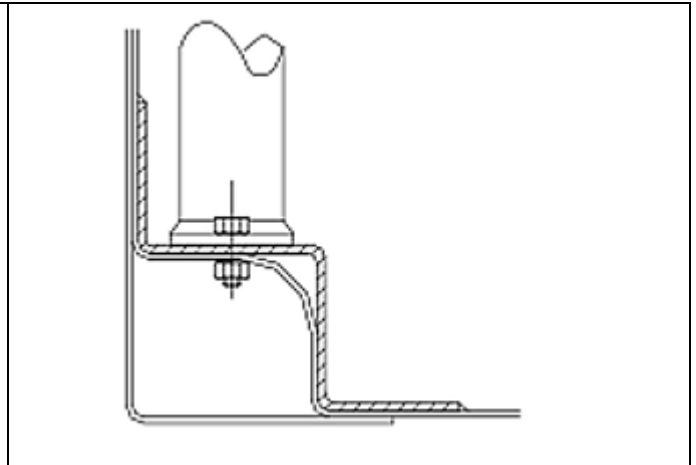

Figure J-65

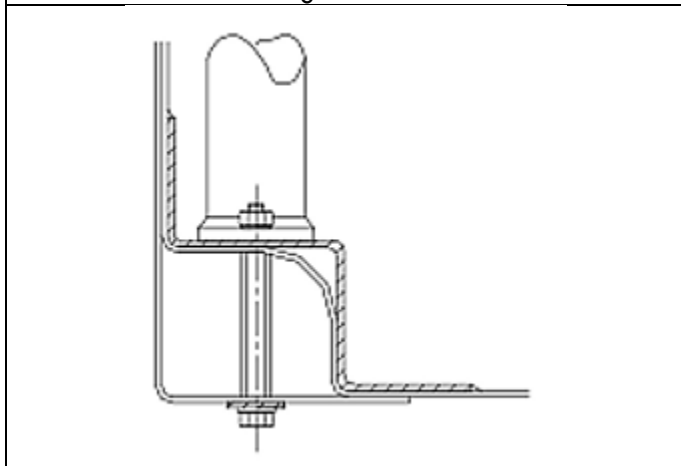

Figure J-66

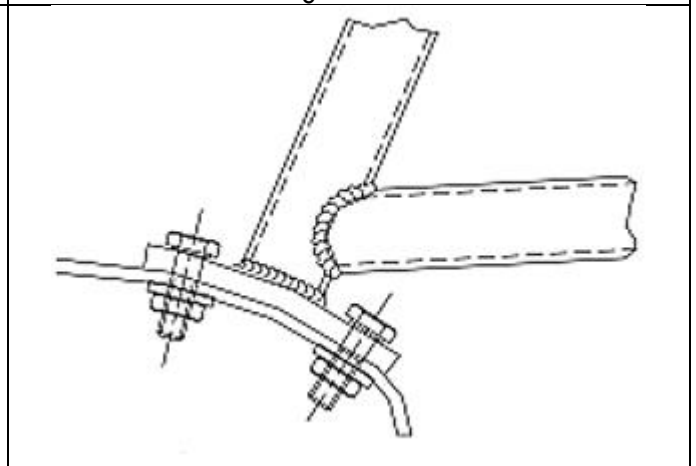

Figure J-67

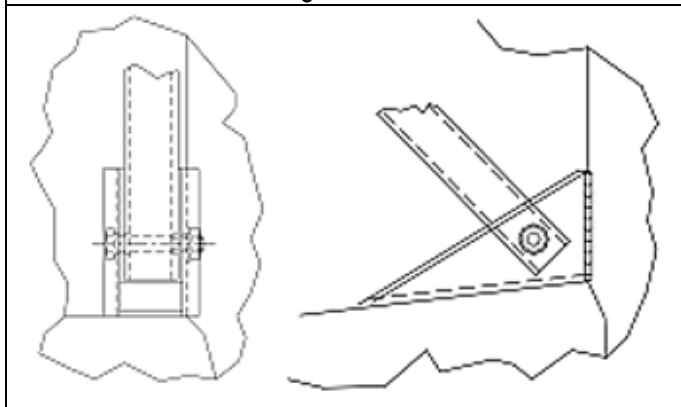

Figure J-68

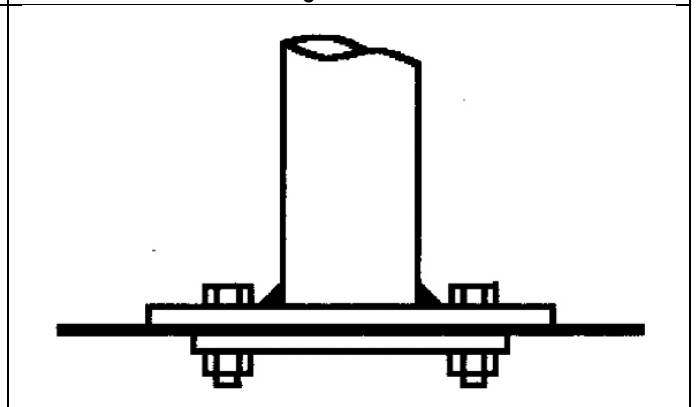
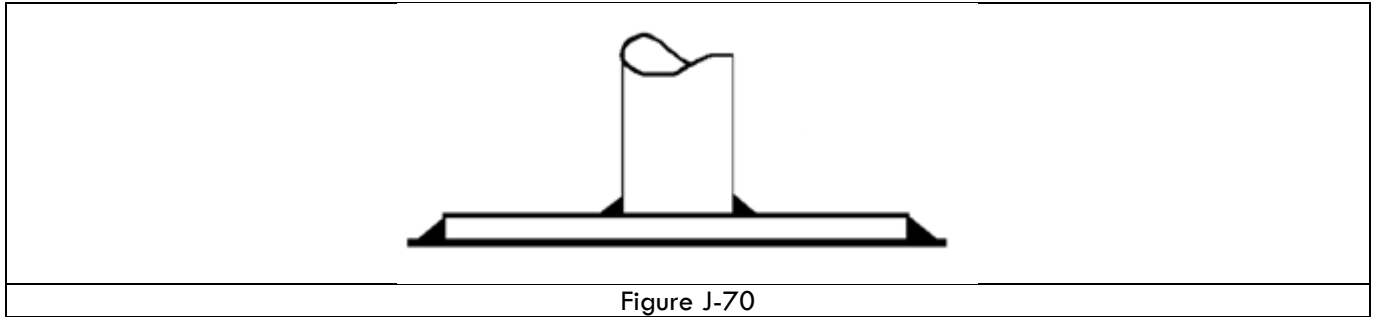

Figure J-69



3.3. BALLAST

Ballast must serve only the unique purpose of adding weight to a vehicle.

A vehicle may have up to 50 lbs. (22.26kg) of ballast weight added to it.

Ballast must be mounted ahead of the rear axle. Blocks must weight no less than 5 pounds (2.26kg) each and cannot be made of liquid of any type, pellets or any other granulated material.

Ballast must be securely bolted in place with a minimum of one .5-inch (12mm) diameter grade 8 bolt.

No weight shifting devices are allowed including but not limited to hydraulic or electronic devices.

4. SUSPENSION AND BRAKES

4.1. FRONT SUSPENSION

OEM front sub-frames and cross members must be stock and available on the exact year make and model that is competing in FORMULA DRIFT.

Original suspension design type must remain: Double wishbone, MacPherson strut etc.

Modified or aftermarket suspension parts, including hubs, are allowed.

Suspension relocation brackets that move suspension points or pivots regardless if they are bolt in to the chassis will not be allowed.

MacPherson strut upper mount pivot must remain within the centerline dimension of the OEM unaltered factory bolt pattern on the chassis. Refer to Figures 6 and 7. The OEM pattern on the chassis must remain unaltered and be the only means of mounting the upper strut mount. All OEM bolt holes must be present and utilized. Vehicles with



YOUR DRIFT SUSPENSION SOLUTIONS



WWW.WISEFAB.COM

MacPherson upper strut mounts not represented in the illustration must contact the Formula Drift Technical Department.

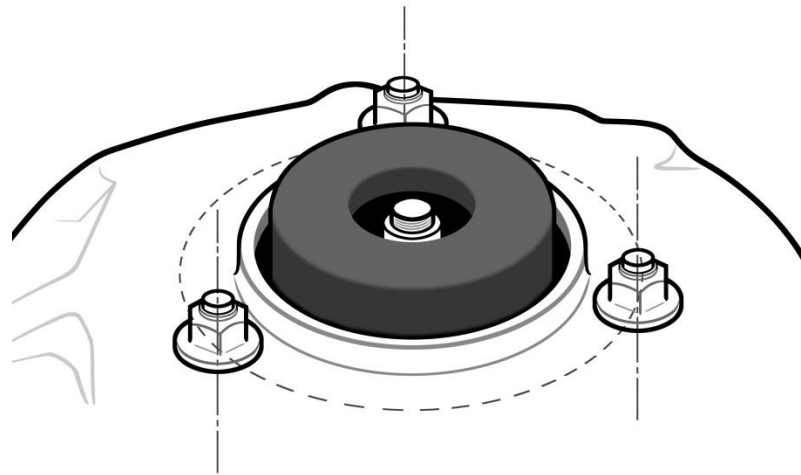

Figure 6

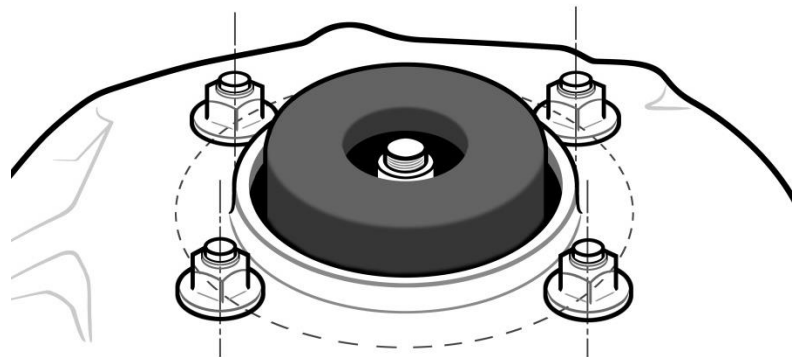

Figure 7

Front subframe must remain in the factory location: no relocation of the subframe on any plane will be allowed

All original suspension mounting tabs must remain in the original position. NO cutting, welding, bending, drilling or modifications of any kind will be allowed.

Front subframes may only be modified to directly allow for oil pan/ starter clearance and steering rack relocation. The front subframe must retain intact on at least one major member on one face that spans the entire width of the subframe, thereby keeping the original dimensions of the subframe intact. Any other modifications, cutting, welding, strengthening, etc is not allowed.

4.2. STEERING

Modifications of steering components (steering rack, tie rods, etc) are free. This includes mounting the rack to the front subframe.

4.3. REAR SUSPENSION- LIVE AXLE

The original chassis mounting points must remain unaltered and in the original factory position. Suspension relocation brackets that move suspension points or pivots regardless if they are bolt in to the chassis will not be allowed.

Original suspension design must remain: 3 link, 4 link, etc.

4.4. REAR SUSPENSION- INDEPENDENT

OEM Rear sub-frames and cross members must be stock and available on the exact year make and model that is competing in FORMULA DRIFT.

Original suspension design type must remain: 5 link, 4 link, strut, etc.

Modified or aftermarket suspension parts, including hubs, are allowed.

Rear Subframe to chassis dimension table has been omitted for 2015 International Rounds

All original suspension mounting tabs must remain in the original position. NO cutting, welding, bending, drilling or modifications of any kind will be allowed including subframe bushing to chassis mounts.

Additional mounting tabs may be added to relocate the suspension arm mounting points a maximum of 2 inches (50.8 mm) on any plane from the original mounting position

This will be measured center to center from the original pivot point to the new pivot point. Please refer to Figure 8. This rule only applies to vehicles with a rear subframe

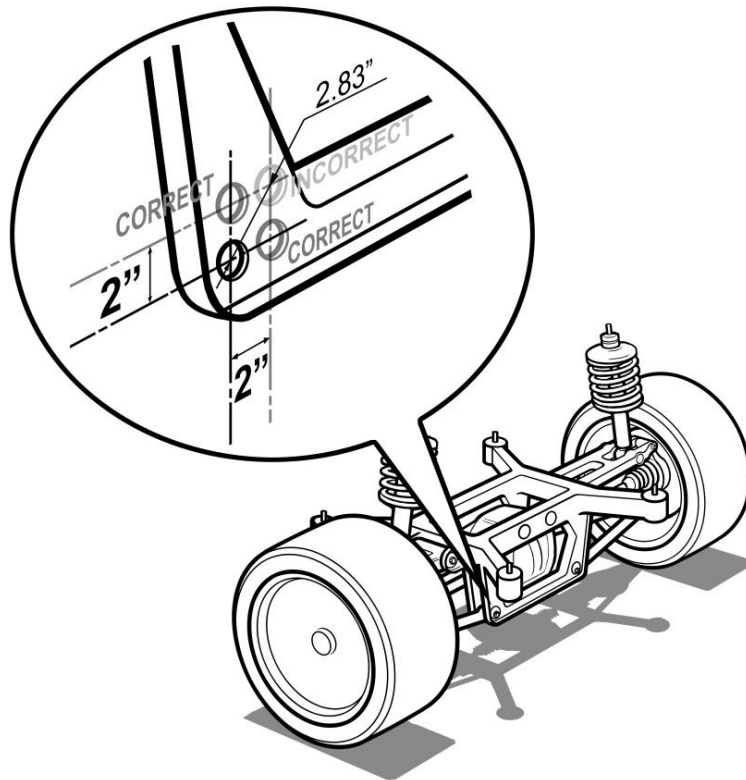

Figure 8

Rear subframes may be modified to allow for mounting or relocating a differential. The rear subframe must retain at least one major member that spans the entire width of the subframe, thereby keeping the original dimensions of the subframe intact. Any other modification(s) such as cutting, welding, strengthening, etc is not allowed.

4.5. BRAKE SYSTEM

The primary brake system must operate all 4 wheels.

Dual master cylinders pedal assemblies are allowed.

Driver adjustable brake bias is allowed.

Secondary hydraulic e-brake systems are allowed either as a fully separate system or as a pass through system.

Secondary Brake system / E-brake must only operate the rear wheels.

4.6. Wheels

Beadlocks, wheel screws and any additional form of attachment device between wheel and tire is prohibited.

5. DRIVETRAIN

5.1. ENGINE

Engine substitutions and modifications are free, but may only run on gasoline, diesel, and ethanol blends. All other fuels require written approval from the technical manager.

All fluid systems must be free of leaks.

5.2. COOLING SYSTEM

Cooling system modifications are free but must be fully closed and free of leaks.

Automatic water sprayers will be allowed during competition, but must not be leaking on the track, starting line, or grid area.

If cooling system lines are routed in the driver's compartment or a trunk area that is open to the driver, they must be separated from the driver by a crushable metal enclosure made up of .036-inch steel, or .059 inch aluminum. The floor of the enclosure must be designed to prevent accumulation of fluids.

Cooling systems shall be filled with water only. "Water wetter" is allowed.

Radiator catch tanks with a minimum capacity of one (1) quart are required. Catch tanks must be securely fastened and sealed from the driver's compartment.

5.3. OIL SYSTEM

Oil system modifications are free but must be fully closed and free of leaks.

If the oil tank is located in the driver's compartment area, or a trunk area that is open to the driver, it must be separated from the driver by a metal enclosure made up of .036-inch (.9144 mm) steel, or .059-inch (1.4986mm) aluminum.

The floor of the enclosure must be designed to prevent accumulation of fluids.

Oil catch tanks with a minimum capacity of one (1) quart are required. Catch tanks must be securely fastened and sealed from the driver's compartment.

All engine components and exterior components that support engine operation such as oil cooler, Accu-sump, dry-sump tank, oil filter, and oil lines must be protected and within the confines of the factory frame rails and factory bumper or tubular bumper structure.

5.4. FUEL SYSTEM

FUEL TANK/ CELL

The fuel system design is free, but engines may only run on gasoline, diesel, and ethanol blends. All other fuels require written approval from the technical manager.

Safety Fuel cells are required for all vehicles with a relocated fuel tank. Safety fuel cells shall consist of a bladder enclosed in a metal container. If the factory fuel tank is retained it must be mounted in the factory location in the factory manner while being enclosed by the factory sheet metal.

BAKER EST 69

PERFORMANCE RACING PRODUCTS

WWW.BAKERPRECISION.COM

2865 Gundry Ave
Signal Hill, CA 90755
562 427 2375
M-F 9-5

Call for special hours during
FDLB and FDIRW



PLUMBING

E85 Compatible Hose,
SS Braided Hose,
AQP Socketless Hose,
Hose Ends,
AN Fittings & Adapters



SFI

Roll Bar Padding



- Coolers
- Fans
- Gold Foil
- Fire sleeve
- Battery Cut off Switch
- NEO Lubricants
- Tire pressure gauge
- Batteries

WWW.BAKERPRECISION.COM



Made to your spec while you wait!

Brake Lines
Clutch Line
Turbo Feed Line
E Brake line

Supporting the Drifting
Community & FD Drivers
for over 10yrs



Drag race style fuel cells with bottom mount sumps and or fittings are prohibited. Fuel cells meeting SFI 28.1 are recommended.

Fuel tank/cell must be separated from the driver's compartment by a permanently mounted steel or aluminum bulkhead. The bulkhead in a hatchback vehicle must be affixed to the chassis and no movable structure or panel such as the hatch will be allowed as part of the bulkhead. Fuel cells may be installed in the interior of the vehicle, preferably within the confines of the roll cage structure.

The floor pan may be modified to fit a fuel cell and lines.

Fuel cells must have a flapper valve installed to prevent spillage in the event of a roll over.

FUEL LINES

Fuel lines and fittings must be high-pressure type and routed in such a way that do not interfere with moving parts and be securely insulated and attached to the unibody or chassis.

No fuel lines may be routed through the driver's compartment.

Teams may install dry-break fuel-filler attachments in the rear quarter windows or into the rear windshield or trunk lid to facilitate re-fueling from outside the vehicle.

The fuel filler tube between the fuel filler neck and the fuel cell, or tank, must be bulk-headed with .036-inch (.9144 mm) steel or .059-inch (1.4986 mm) aluminum and sealed. There shall be a flexible tube between the fuel filler neck and the fuel cell/tank to allow for misalignment of the tube as the result of an accident as well as a one-way "flapper" valve.

5.5. NITROUS OXIDE

Nitrous Oxide bottles must be securely mounted and protected within the confines of the factory frame rails and factory bumper or tubular bumper structure. The use of plastic bottle brackets is prohibited. Nitrous bottles located in the passenger compartment must have a pressure relief valve and be vented to the outside of the passenger compartment.

5.6. EXHAUST SYSTEM

Exhaust system modifications are free, but must pass the rear axle or in the original location. Mufflers are not required.

5.7. STARTER

All vehicles must be equipped with an on-board starter and power supply which must be in working order at all times

5.8. TRANSMISSION

All vehicles must be equipped with a functioning reverse gear

Transmission and/or final drive modifications are free, but only the rear wheels may propel the vehicle.

5.9. DRIVESHAFT

Driveshaft retaining loop is recommended, but not required for 2015 International Rounds. Drive shaft retaining loop must be mounted within 6 inches (152.4 mm) of the forward most universal joint and be securely attached to a body or frame structure as in Figure 9. The driveshaft loop may be made of minimum .250-inch

(6.35 mm) x 2-inch (50.8 mm) wide steel strap or .875-inch (22.225 mm) x .065-inch (1.651 mm) steel tubing and be securely mounted in case of universal joint failure.

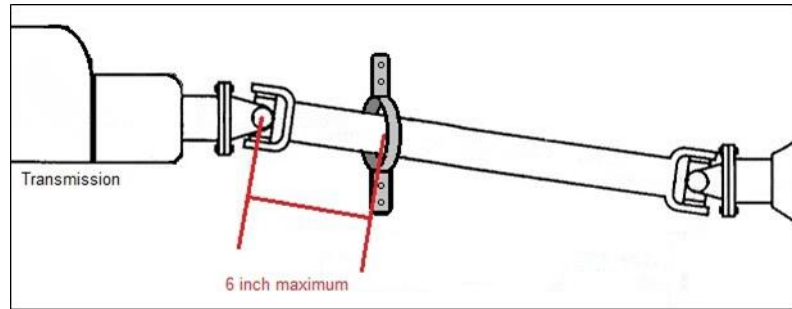

Figure 9

5.10. TRACTION CONTROL

Traction control and other non-specified “driver aids” are not allowed. Including but not limited to speed sensors, linear transducers, driveshaft rpm, and steering position. Wheel speed and driveshaft sensors must be removed.

5.11. DATA

FORMULA DRIFT may require some or all vehicles to have Data Acquisition systems installed. These systems may be used for judging or for technical purposes.

Any data collected is the property of FORMULA DRIFT, and discretion will be used to keep it confidential between the team and FORMULA DRIFT as necessary, however data used for judging purposes may be disclosed to other teams as appropriate.

If required, detail regarding sourcing, installation, and operation of a Data Acquisition system will be referenced in official FORMULA DRIFT publications including but not limited to Supplemental Regulations, Bulletins or Memos.

6. ELECTRICAL SYSTEM

6.1. BATTERY

The battery must be securely mounted and the positive terminal completely insulated to avoid contact with any other metal parts.

Batteries may be relocated. Relocated batteries must be fastened to the frame or unibody with a minimum of two 3/8-in diameter bolts. J bolts or hooks are prohibited.

If the battery is located in the driver’s compartment, it must in a sealed box bolted to the unibody/chassis with the battery securely fastened inside the box and properly vented and drained. Refer to Figure 10

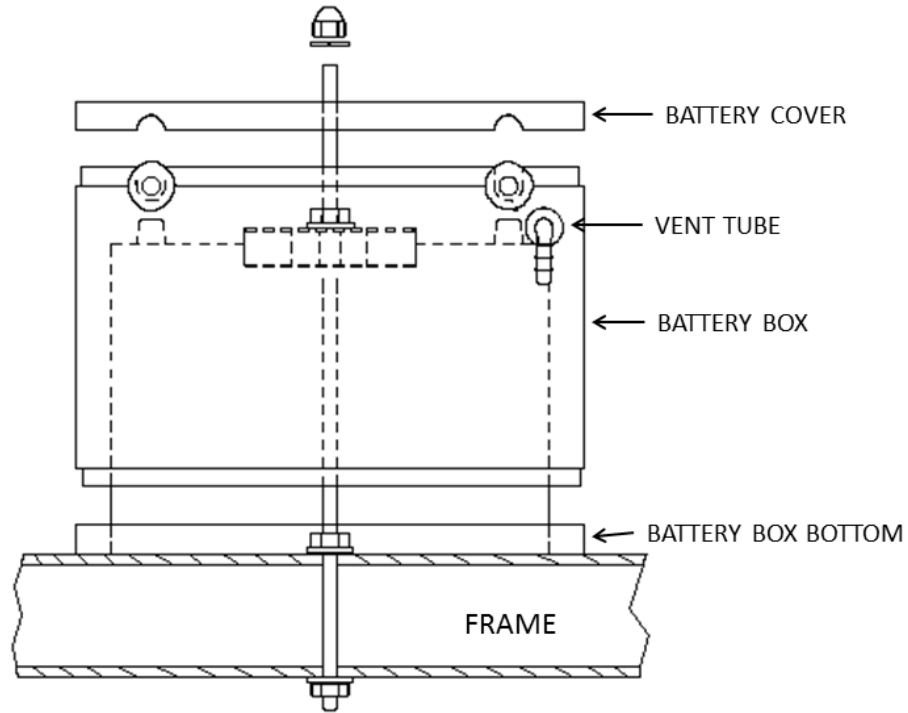

(2) 3/8" THREADED RODS TO PASS THROUGH BATTERY BOX AND HOLDDOWN TO SECURE THE BATTERY TO THE VEHICLE'S FRAME

Figure 10

6.2. MASTER CUTOFF

A Master electrical cutoff switch, wired to completely shut off all engine and electrical system function except for electrically operated fire suppression systems is mandatory and must be mounted outside the vehicle, on the right side cowl just below the windshield and is to be clearly marked with the appropriate "OFF" markings.

The electrical terminals of the cut-off switch and/or any relays used in the circuit must be sufficiently insulated.

7. BODY EXTERIOR AND INTERIOR

7.1. BODY PANELS

Vehicles must maintain the OEM look and feel. Panels must be clean, free of damage and presentable for competition.

All bodywork must be painted or covered and securely attached to the vehicle.

Aftermarket body panels, front and/or rear fascias, side skirts and wings are permitted. One piece front ends are not permitted.

Over fenders are permitted and should be installed as in Figure 11.

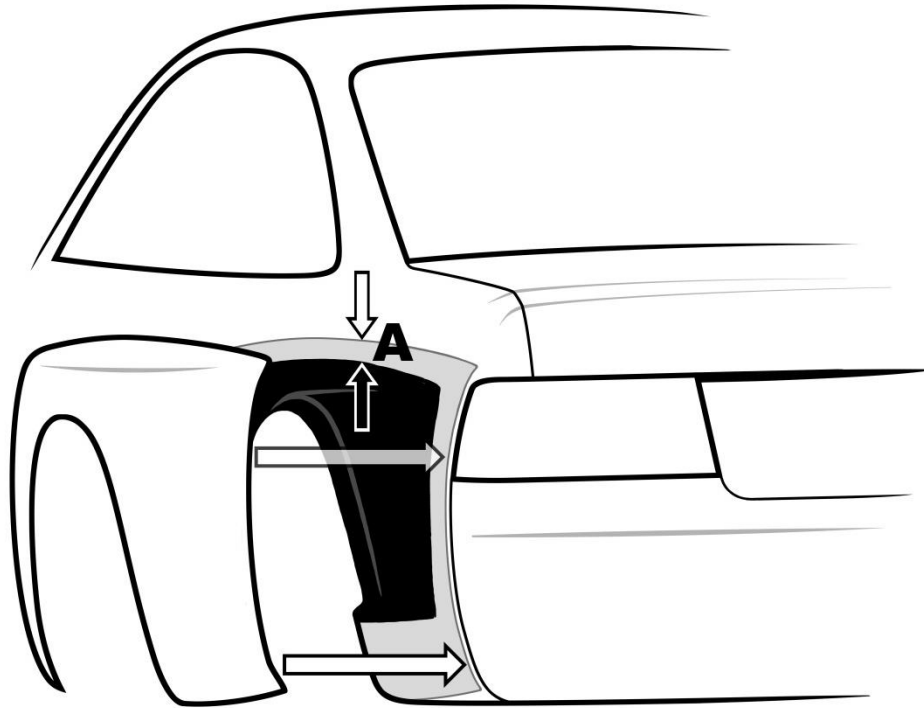

Figure 11

Dimension A: 1 inch (25.4 mm)

Body work that is not designed as O.E.M. or an O.E.M. replacement of the original make and model of the vehicle must be approved by the TECHNICAL MANAGER.

The outside door latch/lock operating mechanism may be removed or modified. If it is not in the original location, the door must be operable from the exterior and the opening mechanism must be clearly visible and/or marked. The inside door latch/ lock operating mechanism must be functional and readily accessible for the driver to exit the vehicle.

7.2. WING (Section omitted for 2015 International Rounds)

7.3. WINDSHIELD

Windshields must be installed and OEM glass or OEM replacement material and be free of cracks. Non-glass, Lexan/polycarbonate replacement windshields must be a minimum thickness of .1875-inch (4.765 mm) securely mounted and have a vertical brace made of .0625-inch (1.5875 mm) aluminum and be .750-inch (19.05 mm) wide which is securely mounted down the center of the opening on inside the vehicle.

7.4. WINDOWS and WINDOW RESTRAINTS

Door, quarter and rear window must be OEM glass, clear/polycarbonate with minimum thickness of .125-inch (3.175 mm) and securely bolted in place. Side windows shall have a window net, clear O.E.M. glass, or a piece of clear Lexan/polycarbonate in place of both front window openings whenever the vehicle is on-track. Competitors may choose to use arm restraints in lieu of side windows or a window net. Competitors with convertible vehicles must use arm restraints.

7.5. WIPERS

Vehicles must have a functioning windshield wiper.

7.6. MIRRORS

Two external, rear-facing mirrors are required, and must be positioned so that the driver can see objects along both sides of the vehicle.

7.7. HOOD PINS

Two hood pins, equally spaced across the front of hood and are required within 24-inches (609.6 mm) of the leading edge of the hood. The original stock latch must be removed.

7.8. DECALS

All required FORMULA DRIFT and/or other decals or markings must be present in the specified location. FORMULA DRIFT windshield banners are required.

FORMULA DRIFT reserves the right to have any decals, marks, or other items removed or covered at their discretion.

DECAL PLACEMENT

All competing vehicles must carry the following mandatory decals, as well as any other decals as mandated by FORMULA DRIFT via supplemental regulations, memos, and other communications.

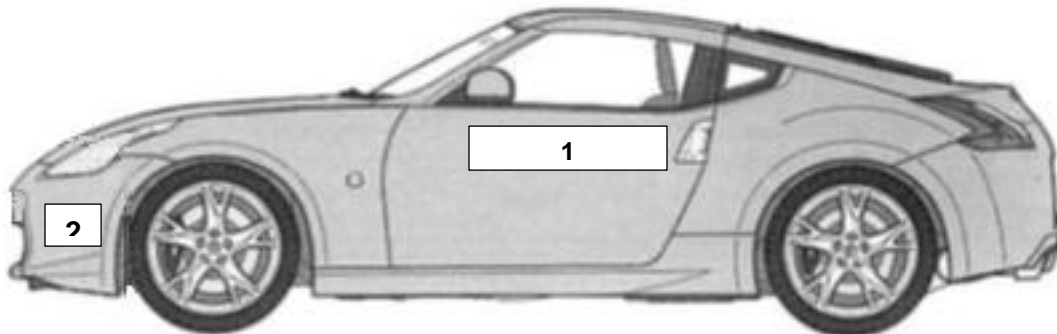

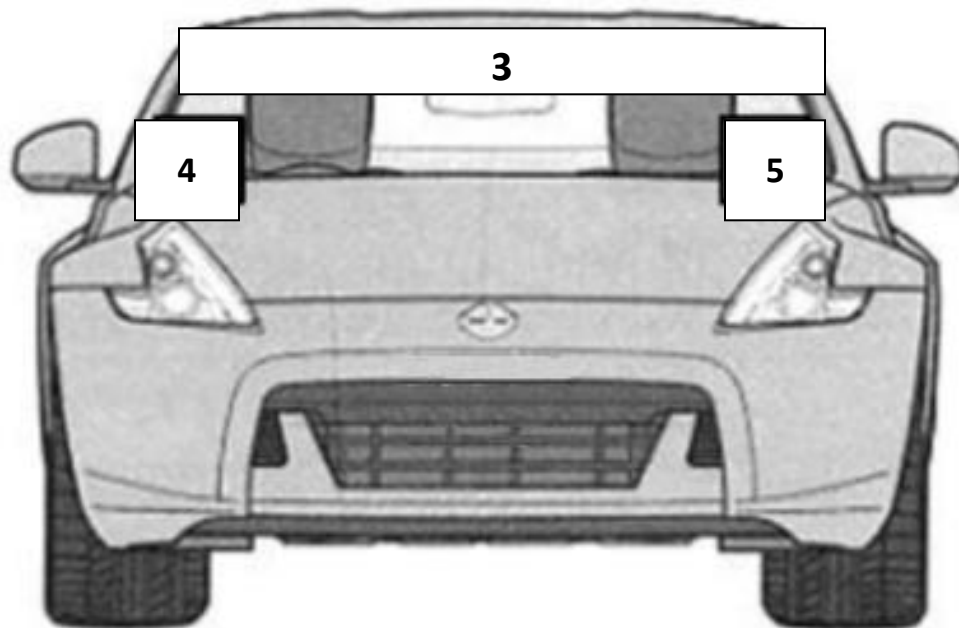

DECAL PLACEMENT KEY

1. (2) Formula Drift Number/ Name Plate 25mm x 25mm from top of door
2. (1) Formula Drift Decal
3. (1) Formula Drift Windshield Banner
4. (1) Formula Drift Decal
5. (1) Competition Result Decals

Competitors may also be required to carry event specific sponsor/ contingency decals.

All vehicles must have the number plate in the designated area above. Any alteration such as cutting or modifying is not allowed. A minimum fine of \$500 per event will be issued to any violators.

7.9. TOWING APPARATUS

Must be equipped front and rear as follows:

Load Rating of not less than the gross vehicle weight

Minimum internal hole diameter of 40mm

If made of a metal it must not protrude more than 75mm from a blunt surface.

Colored in a contrasting color to the surrounding body work

If not clearly visible must that their position clearly indicated by the word "TOW" or an arrow in a contrasting body color

ORACLE[®]

LIGHTING TECHNOLOGY



watch / like / follow @oraclelights

www.oraclelights.com

1 (800) 407-5776

7.10. LIGHTS

OEM LIGHTS

All OEM lights must remain in place. Brake lights and tail lights must be red. Taillights must remain in OEM condition tinting is prohibited. Use of rearward facing strobe lights of any color is strictly prohibited. Headlights must function normally. Use of red headlights is prohibited. The use of electrical, mechanical, and or hydraulic cutoff switches, relays, or any other device that renders the brake lights inoperative in any way, is strictly prohibited.

FRONT BRAKE LIGHT STRIP / THIRD BRAKE LIGHT STRIP

Brake Light strips should be mounted on the roof above the windshield and the rear window on a fixed non removable panel or structure. Brake light strips are available from Formula Drift. They are 36 inches (914.4 mm) long LED strips and must remain 36 inches (914.4 mm) long. The light must be connected to the existing brake light circuit.

7.11. INTERIOR

The interior of the vehicle must be clean and professional in appearance.

All non-essential and/or loose items must be removed.

All carpeting and/or sound deadening material must be removed.

Supplemental Restraint Systems (SRS) must be removed.

7.12. DASHBOARD

The dashboard must be either stock or stock replacement. Replacement must be same dimension, appearance, and position of stock dashboard.

7.13. STEERING WHEEL

Any steering wheel except wood rimmed may be used.

8. DRIVER'S SAFETY EQUIPMENT

8.1. HELMET

All occupants must wear a safety helmet during on-track sessions. Only helmets certified to meet the following standards are permitted:

Snell Memorial Foundation – SA2005, SA2010,SAH2010

SFI Foundation – Spec 31.2, Spec 31.2A

FIA 8860-2004, 8860-2001

Full-faced helmets are required.

Helmet chin straps must be buckled or fastened while on course.

Hair protruding from beneath a driver's helmet must be completely covered by fire-resistant material. Drivers with facial hair must wear face shields of fire-resistant material (i.e. balaclava or helmet skirt).

Accident-damaged helmets shall be given, or sent, by the driver, or his representative, to FORMULA DRIFT. It will be forwarded to the certifying organization for inspection. Details of the accident should be included.

8.2. DRIVING SUIT

One-piece driving suits are required and must be made of fire-resistant material and certified to SFI spec 3.2/A/5 or greater, or homologated to FIA 2000 specs, which effectively covers the body, including neck, ankles and wrists. Multi-layer driving suits are recommended.

Gloves, shoes, and socks are required and must be fire-resistant material and certified to SFI spec 3.3/5 or greater, or FIA 8856-2000 specs. Articles must be free of holes, tears or other openings except those made by the manufacturer of the equipment.

Fire-resistant underwear is recommended.

All drivers and teams must carry a FORMULA DRIFT series Logo on the uppermost chest of the driver's suit and team uniform. Other official series sponsor patches may be required. Contact the FORMULA DRIFT office to obtain a digital file or patch.

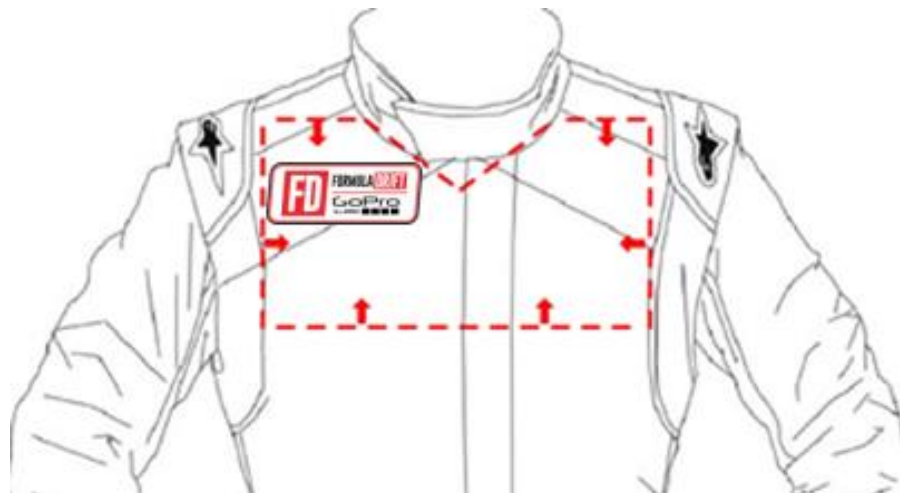

8.3. EYE GLASSES

Any corrective eyeglass material used shall be of safety glass-type, and meet U. S. Government standards.

8.4. SEATS

All vehicles must have at least two seats, one for the driver, and one for a passenger. Each of the two required seats must be homologated to FIA standard 8855-1999.

“Halo style” driver’s seats are not required, but recommended for 2015 International Rounds.

The usable life of an FIA homologated seat is 5 years from the date of manufacture indicated on the seat label.

Sample FIA seat homologation label:

	In compliance with : FIA Standard 8855-1999
	Manufacturer Name : Name of Manufacturer
Serial n° :	xxx xxx
Model :	Model Name
Homologation N° :	CS.xxx.xx
Date of Manufacture :	MAY 2012

The homologation labels must be visible

SEAT SUPPORT

Seat supports shall be of the type listed on FIA technical list No.12 (lateral, bottom, etc).

MOUNTING HARDWARE

All hardware used in the mounting of seats, or other structural supports shall be SAE Grade 5 or better with a 5/16" minimum diameter.

8.5. SEAT BELTS

All occupants shall utilize a driver restraint system that conforms to these regulations.

All occupants in FORMULA DRIFT EVENTS must utilize either a **four-point (allowed for 2015 International rounds)**, five-point, or six-point, restraint harness meeting the following specifications at all times during practice, qualifying, and the race.

A minimum four-point system is required for use in automobiles is required for 2015 International rounds.

The system consists of a two or three in lap belt, three-inch shoulder straps or two-inch shoulder straps when used with an approved SFI 38.1 Head and Neck Restraint.

All Harness belts must meet either SFI or FIA Homologations:

There shall be a single release common to the lap belt, shoulder belts, and sub-strap harness.

SFI Certification – Harness systems may be certified to SFI spec 16.1 or 16.5 and shall bear the appropriate label(s) on shoulder belts, lap belts and sub-straps. Each harness is punched with the year and month of manufacture. This certification shall expire (2) years after the punched month and date on the belt.

SFI 16.1 belts must have a 3 inch lap belt. 2 inch Head and Neck Restraint specific shoulders are permitted when used with an approved SFI 38.1 Head and Neck Restraint.

SFI 16.5 belts may have a 2 or 3 inch lap belt. 2 inch Head and Neck Restraint specific shoulders are permitted when used with an approved SFI 38.1 Head and Neck Restraint.

FIA Certification –Harness systems may be homologated by the FIA to specification **8853/98 or 8854/98**, and shall bear the appropriate label(s) on each element of the belt. FIA belts are dated with an expiration year with the belts expiring on December 31st of the year punched or printed on the FIA tags. FIA belts have a certification period of 5 years plus the remaining months of the year purchased.

Regardless of the date of manufacture, the safety harness shall be replaced if the webbing is cut/ frayed, if any of the buckles are bent/cracked, if the vehicle has been in a severe impact, or at the direction of the TECHNICAL MANAGER. If any of these conditions exist, the TECHNICAL MANAGER shall cut the certification labels off of the harness. The team will then have to replace the belt.

Only separate shoulder straps are permitted. “Y-type” and “H-Type” configurations are not allowed. Sternum straps connecting the two shoulders belts over the chest are not allowed. The shoulder harness shall be mounted as closely behind the seat back as possible, not to exceed twelve inches (12”). The shoulder harness shall be above a line drawn downward from the shoulder point at an angle of no more than 20-degrees with the horizontal and shall not be above 0-degrees. The shoulder straps shall pass through the seat back when the occupant is seated, without interference (up, down, or side to side), to the attachment points. (Figure 1).

The lap belts shall be mounted rearward of the pelvis, between two lines drawn at 45-degrees, and 80-degrees, below the horizontal with the optimum angle of 60-degrees (Figure 1). The lap belts shall pass through the seat, without interference, from the attachment points and should ride over the pelvis, just below the pelvic crest, to the buckle. The top of the buckle should be positioned at least 1-inch below the belly button. The lap belt attachment must allow the lap belt to pivot at the mounting point to prevent the webbing from being loaded at an edge when loaded and must pull on the hardware in plane.

The minimum acceptable bolts used in the mounting of all belts end harnesses are SAE Grade 5. Where possible, seat belt, shoulder harness, and anti-submarine strap(s) should be mounted to the roll structure, or frame of the vehicle. Where this is not possible, large diameter mounting washers or equivalent should be used to spread the load. Bolting through aluminum floor panels, etc., is not acceptable.

The single or double anti-submarine strap(s) shall be attached to the floor structure of the vehicle and have a metal-to-metal connection. Bolts through the floor pan must use a backing plate on the underside of the body. If the chassis does not have a steel floor pan, other provisions must be made to provide a steel plate or bar traversing the frame rails and transmission tunnel of sufficient strength to take a minimum load of at least 1,200lbs for each mounting point.

All seat belt systems are to be mounted according to the manufacturer’s instructions or to the *SFI Guide to Seat Belt Mounting* (Figure 2)

If “3-bar” adjusters are used for a lap or shoulder belt, they shall be placed as close to the mounting points as possible and must be wrapped with the final loop (Figure 4). Straps utilizing a hook with a spring-loaded clip, which attaches to an eyebolt, must use a cotter pin, or safety wire, through the small hole that prevents the clip from opening.

Occupants of convertible vehicles must use arm restraints.

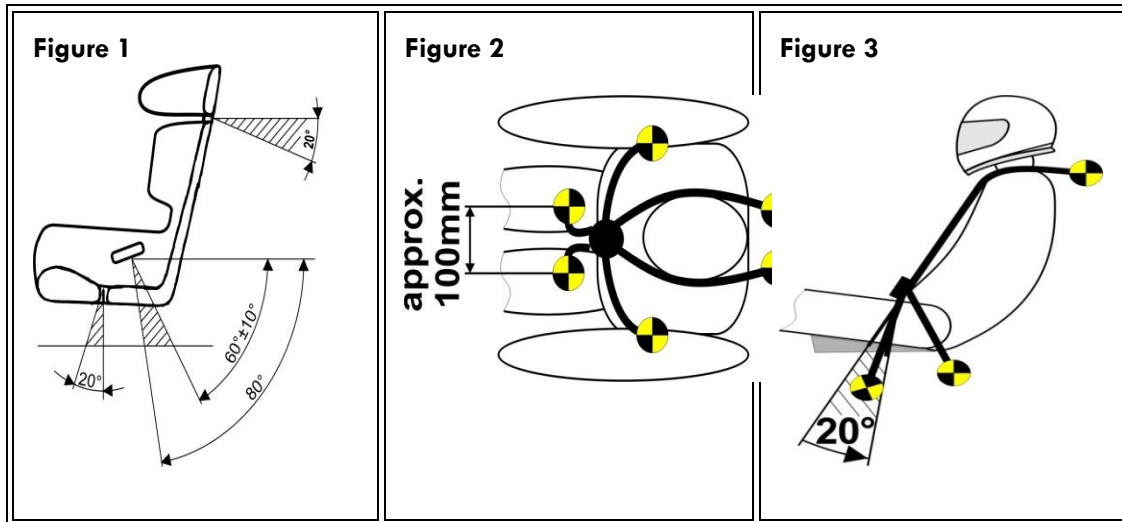

The figure below is the preferred method for harness attachment to harness bar.

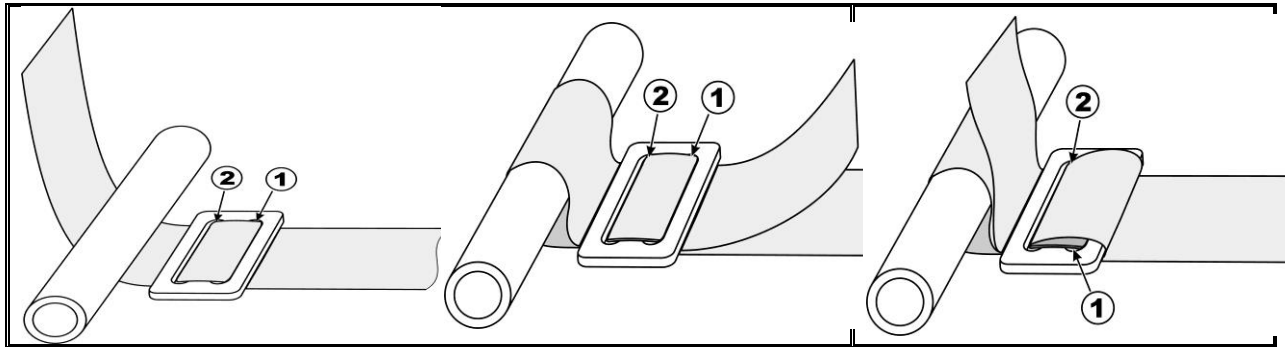

8.6. ARM RESTRAINTS

Competitors may choose to use arm restraints in lieu of windows or a window net. Competitors with convertible vehicles must use arm restraints.

8.7. HEAD AND NECK RESTRAINTS

A Head and neck restraint certified in accordance with SFI 38.1, FIA 8858-2002 or 8858-2010 **are not required, but recommended for 2015 International Rounds.**

SFI 38.1 devices must be recertified by the manufacture or authorized manufacturer representative every 5 years. Each certification is good for 5 years from the month and year punched on the SFI label.

FIA 8858 devices do not require recertification however the dating year printed on the tether must not be more than 5 years old.

After any significant impact, it is recommended that the device tether be replaced.

8.8. FIRE SUPPRESSION

On-board fire suppression systems are not required, but recommended for 2015 International Rounds.

All cars must have an on-board fire extinguisher in accordance with the table below.

EVENT TYPE	APPROVED EXTINGUISHANT	TYPE	MINIMUM QUANTITY	MINIMUM FIRE RATING	SERVICE / VALIDITY
Drifting	Powder BE or ABE (refer Note 3)	Stored pressure with gauge (refer Note 1)	.9kg	5 B	6 years (refer Note 2)
	Foam AFFF / AR-ARFF / AR-FFFR		1.0 liter	5 B	As per manufacture instructions
Notes:					
<ol style="list-style-type: none"> All extinguishers must have a pressure gauge. The indicator must indicate in the operable range (usually a green sector on the gauge). All extinguishers must be checked on a regular basis by the vehicle owner / competitor to ensure contents pressure and approximate weight requirements are met. Dry Powder extinguishers should be agitated from time to time to ensure the powder has not compacted. 					

The mounting bracket must be a quick-release type mounted within reach of the driver while in the normal seated position with his/her harness fastened.

Fire extinguishers must be current and inspection and/or recharge requirements cannot be expired.

9. TIRES

9.1. TIRE ELIGIBILITY (Section omitted for 2015 International Rounds)

9.2. APPROVED TIRES (Section omitted for 2015 International Rounds)

9.3. TIRE SIZE REGULATIONS (Section omitted for 2015 International Rounds)

9.4. TIRE TO WEIGHT COMPLIANCE (Section omitted for 2015 International Rounds)

9.5. TIRE MEASURING PROCEDURE (Section omitted for 2015 International Rounds)

9.6. TIRE MODIFICATION

Any attempt to modify tires in any manner is prohibited. "Grooving" or "Shaving" of tires is prohibited.

The use of traction compounds or any other substance that may alter the physical properties of the tire are prohibited.

Tire warmers or any other means of artificially altering the tire temperatures are prohibited.

Tire balancing with fluids or internal loose weights is prohibited.

9.7. TIRE CLAIMING (Section omitted for 2015 International Rounds)

9.8. REQUESTING TIRE ELIGIBILITY (Section omitted for 2015 International Rounds)

Record of Revisions

DATE:

Release	Current Version	Release Date	Notes

FORMULA*DRIFT* PRESENTED BY
GoPro
Be a HERO. 